

SPEEDY 3000

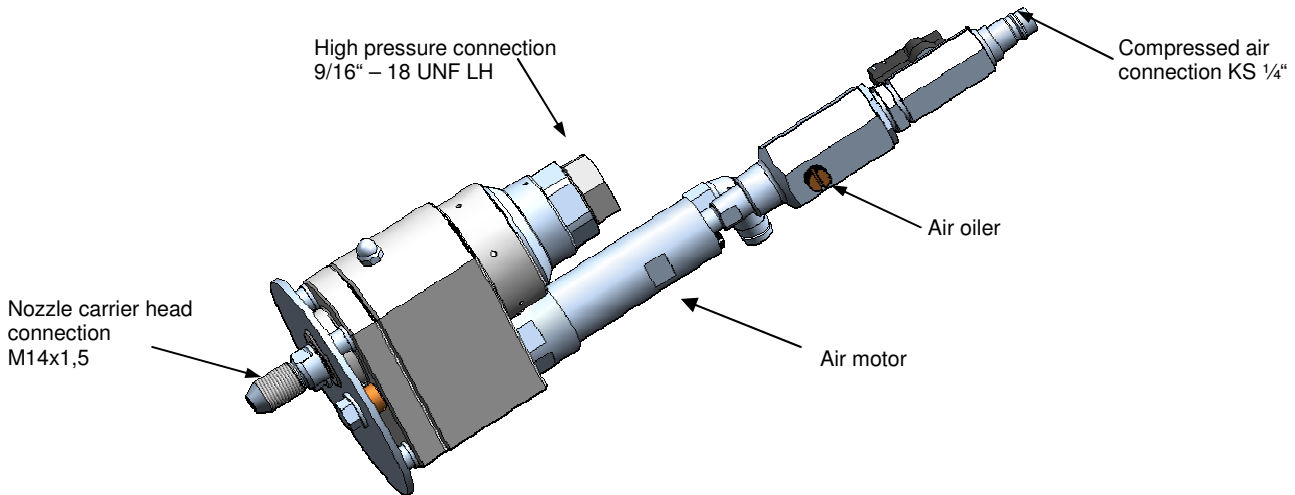

Description:

The SPEEDY is a pneumatically driven rotary lead through with integrated air motor, suitable for a wide range of application.

The composition of HP-Gun, Speedy and Nozzle Carrier Head represents a highly efficient water tool, which guarantees – depending on the rotation of the nozzle carrier head – a high surface treatment/cleaning rate.

Special characteristics:

- Rotational speed adjustable by air pressure and quantity
- Low weight
- Compact design with small dimensions
- Optimum running qualities
- Parts under pressure made of high-tensile stainless steel

Accessories:

- Pressure ring for high pressure connection M14x1,5 LH Part-No.: 320.1799

Technical data:

Part-No.:	001.1770
Operating pressure:	max. 3000 bar
Flow rate:	max. 25 l/min
Medium temperature:	max. +50 °C
Weight:	appr. 2,30 kg
Working pressure of the air motor:	6,3 bar
Performance at working rpm:	0,16 kW 2500 1/min
Air consumption:	0,35-0,4 m ³ /min at 6,3 bar
Sense of rotation:	clockwise in jet direction
Length:	appr. 339 mm
Width:	100 mm



Wasser als Werkzeug für eine saubere Umwelt

SPEEDY 3000 – Components

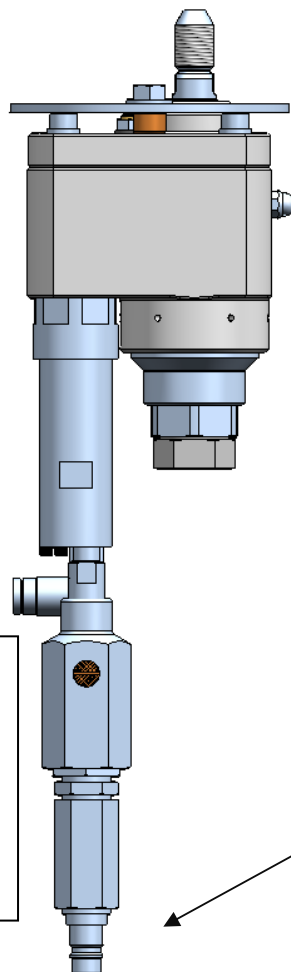
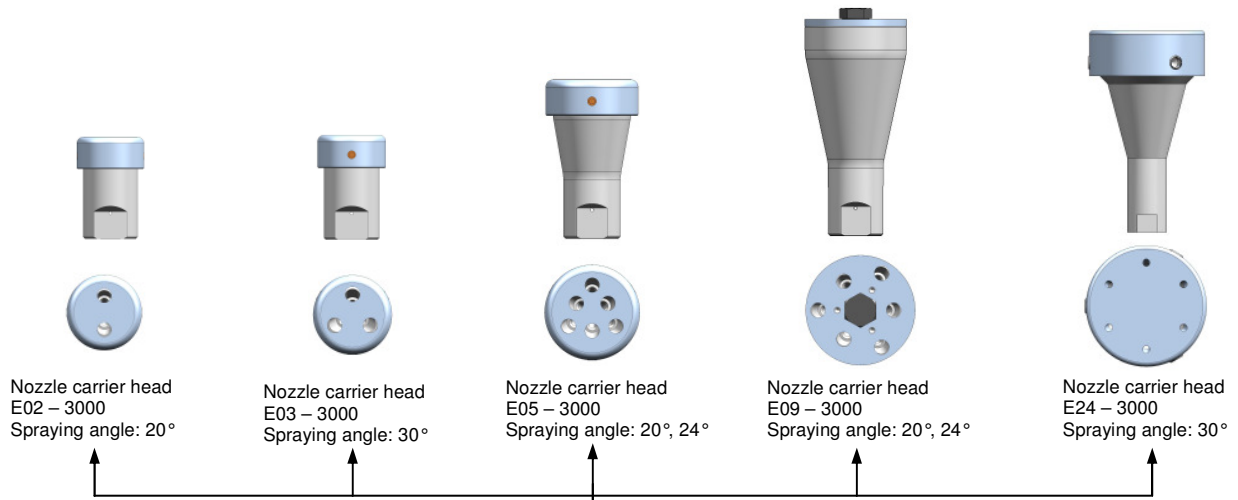

Nozzle carrier head			Weight
Part-No.:	Number of nozzles form 21 LL	Type-bar	kg
341.0585	2	E 02-3000	0,45
341.0586	3	E 03-3000	0,45
341.0583	3 or 6	E 05-2500	0,47
341.0584	3 or 6	E 09-3000	0,85
341.0305	3 or 6	E 24-3000	0,85

Operating information:

The air motor is only to be used with dry, clean and lubricated air.
 Only fill up with pneumatic oil WOMA PN 400.0342 – viscosity class ISO VG 46.
 The max. permitted air pressure of 6,5 bar has not to be exceeded.

Compressed air hose		
Part-No.	Length m	Weight kg
360.2170	10	2,6
360.2129	20	5,0
360.2130	40	9,6

