

Eco Top Rotating Cleaner ETRC 2500-1-PN-F

for pneumatic control with air motor

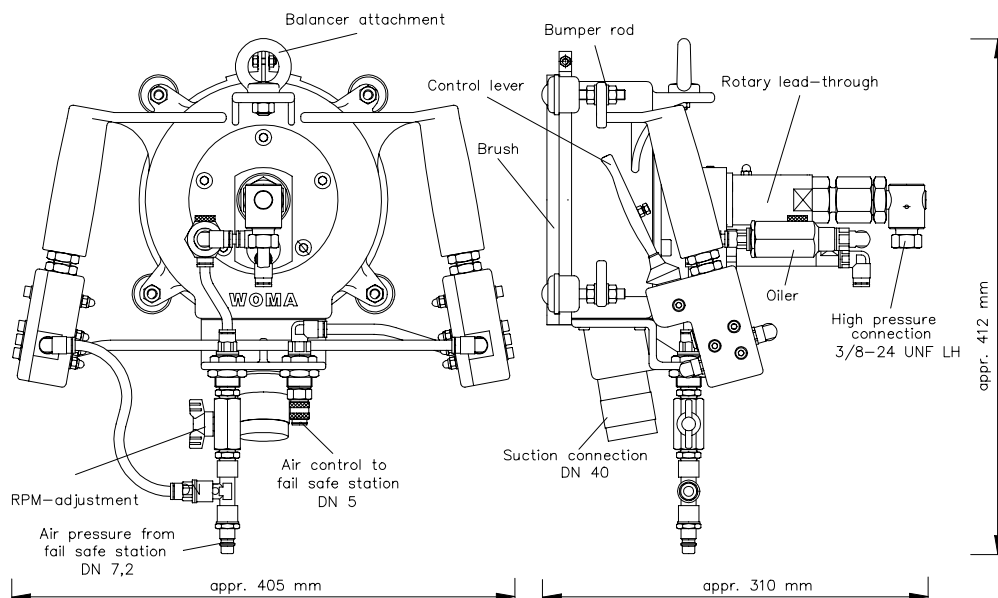

Description:

The ETRC 2500-1-PN-F is a high production hand held tool for the cleaning and removal of paint coatings from large flat areas.

The ETRC version „F“ (air motor driven) gives the operator the flexibility of varying the RPMs of the rotary tool independent of orifice size. With this feature the user more efficiently utilizes the energy of the jets maximizing production and quality of the prepared surface.

Advantages:

The ETRC is delivered vacuum ready for full recovery of water and debris eliminating environmental concerns.

All parts subject to pressure are made of high-tensile stainless steel.

The ETRC can be retrofitted to accept WOMA form 9 fan jet nozzles with retrofit kit PN: 010.8688 (max. 2000bar).

Optimum jet stream when using nozzle form 21LL (LL=LongLife) see product sheet D-21LL-3000.

Operating information:

The rotary operation is not supposed to run without water for longer than 15 sec.

Accessories

Balancer (weight counter balancer) PN 320.3876
see page 2

Technical data:

ETRC 2500-1-E-24V

Part-No.	001.1283
Operating pressure max.	2500 bar
Working width appr.	180 mm
Weight appr.	9,4 kg
Rotating speed max.	2500 rpm
Air consumption	3,6l at 6 bar
Air pressure max.	7 bar
No. of nozzles max.	4 pieces

Recommended nozzle diameters at:

2500 bar and 20 l/min
4 x 0,40mm Form 21LL TN 344.2105

When using nozzle form 21 sapphire, the nozzle diameters must be 0.05mm larger than that of nozzle form 21 LL.



Eco Top Rotating Cleaner Accessories:

Description:

The balancer (Weight counter balance) extends from a cable reel. This cable reel provides constant tension on the entire cable length so that the ETRC is maintained in the desired position. By using the balancer the operator can work effortlessly for long periods.

Advantages:

The automatic locking device has a premature retraction stop at predetermined positions, when the ETRC is slowly retracted. The locking device is not actuated, when the ETRC is retracted quickly. An increase in production is obtained, since the ETRC does not need to be returned to its home position between operational steps.

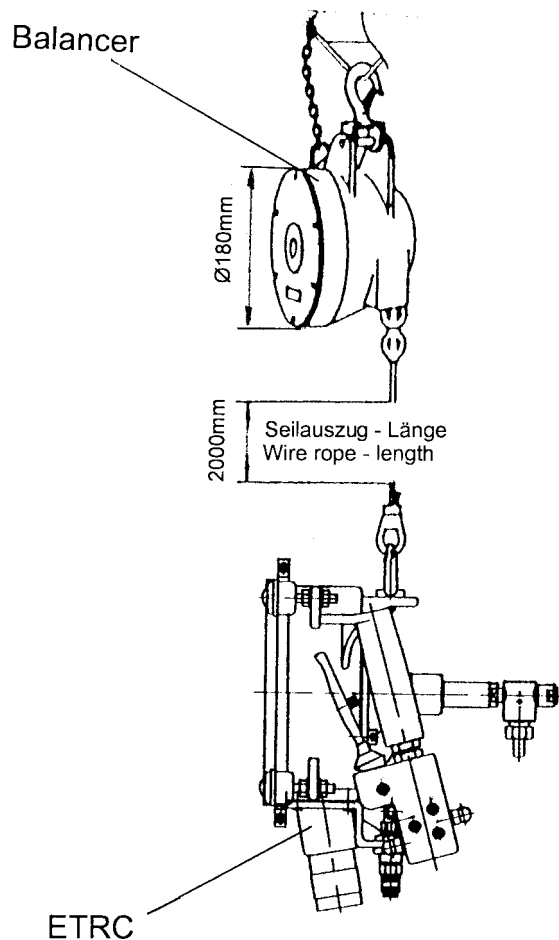

Technical data:

Balancer

Part-No.:	320.3876
Load:	9 – 14 kg
Wire rope length:	2000 mm
Weight:	3,6 kg