

High Pressure Gun

HP 1500S-V-PN

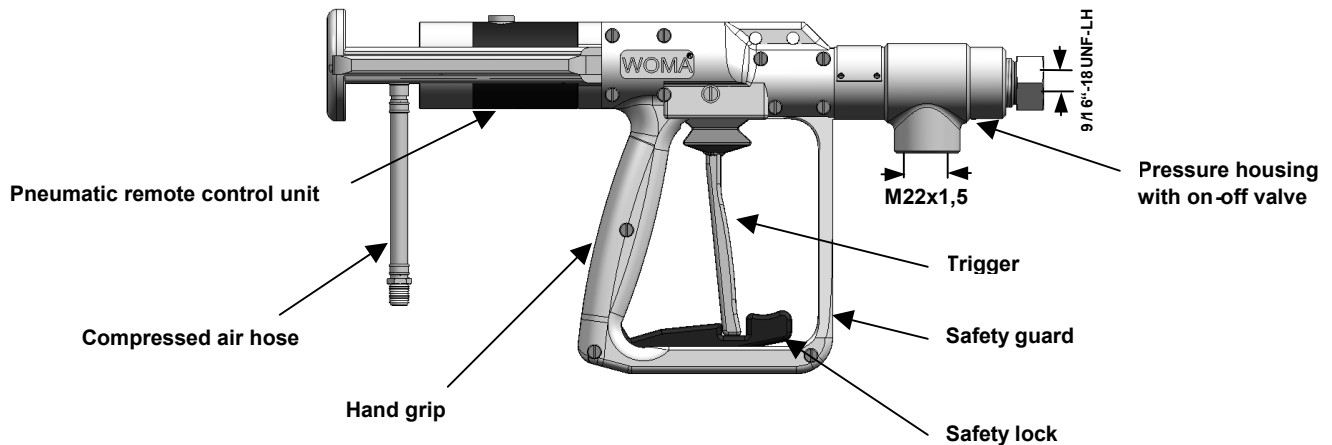

Description:

The HP 1500S-V-PN is a high pressure jetting gun which incorporates a pneumatic control valve and an internal on-off valve into its design.

The pneumatic control valve allows an operator to remotely control additional valves and to trigger complex control systems, which makes operation safer and more comfortable.

Standard equipment includes; A trigger safety guard and latching trigger lock to prevent unintentional use, forged steel pressure housing and light weight polymerized hand grip

Advantages:

High safety standard.

Turnable hand grip.

Fully encapsulated polymerized hand grip offers high tensile strength and excellent resistant to most chemicals.

All functional parts are protected from dirt and water invasion.

Technical data:

Part-No.:	001.1696
Operating pressure:	max. 1500 bar
Medium temperature:	max. + 100°C
Recoil force perm. Without body support:	max. 150 N
Recoil force perm. With body support:	max. 250 N
Weight:	appr. 3,0 kg
Overall length:	appr. 460 mm
Overall height:	appr. 196 mm
Overall width:	appr. 72 mm

High Pressure Gun HP 1500S-V-PN - Components

Nozzle connection	
Part-No.	for nozzle form
010.7275	1 and 8
010.8086	4 and 19
180.1702	21

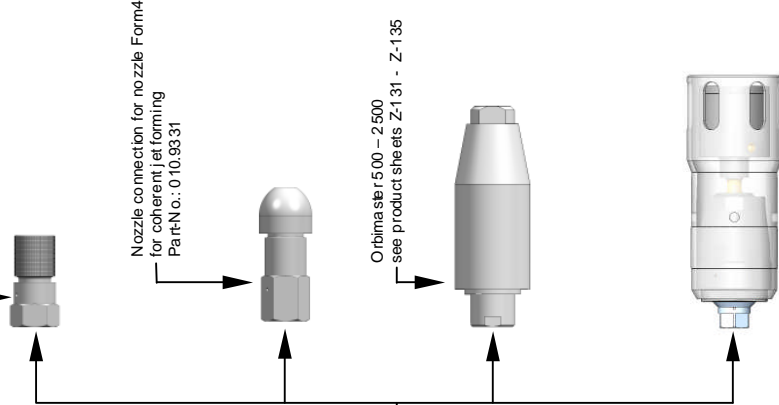

Nozzle connection for nozzle Form4
Part-No.: 010.8331

Orbitasprayer 500 - 2500
see product sheets Z-131 - Z-135

Turbo nozzle TD1000 TD2000
see product sheets Z-147 - Z-148

Nozzle pipe for nominal length L		Weight	C
Part-No.	L (mm)	kg	
445.3346	300	0,26	9/16" - 18UNF LH
445.3347	500	0,43	
445.3348	750	0,64	
445.3349	1000	0,85	
445.3584	1500	1,30	
445.3350	2000	1,69	
445.3351	3000	2,53	
445.3352	4000	3,37	
445.3353	5000	4,21	
445.3354	6000	5,05	
445.4555	7000	5,89	

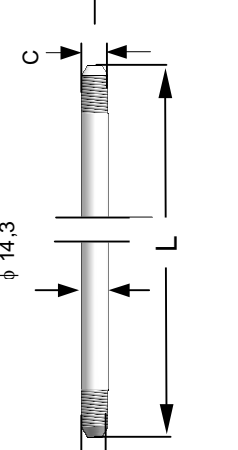

ϕ 14,3

C

L

Hand grip
Part-No.: 010.4923



Hand guard
Part-No.: 011.1947



Gun housing cpl.
HP 1500S-V
Part-No.: 001.1696
Weight: appr. 3,0 kg

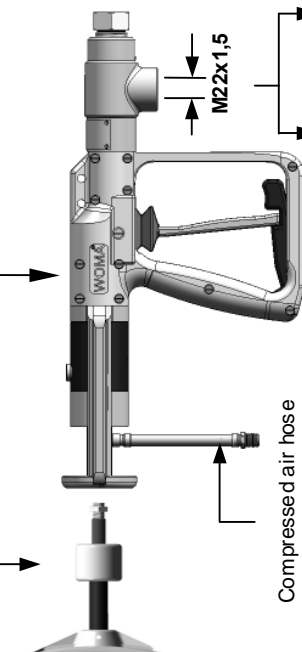

M22x1,5

Turnable hose connection

Part-No.	B
011.0716	M22x1,5 60°DK
011.0717	M24x1,5 24°DK
011.0718	G 1/2 60°DK

Hose connection

Part-No.	A
010.7911	M22x1,5 24°DK
010.7912	M22x1,5 60°DK
010.7913	M24x1,5 24°DK
010.7914	G 1/2 A 60°DK
010.7915	G 3/4 A 60°DK

Compressed air hose

Part-No.	Length (m)
360.2524	10
360.2523	20
360.2576	40

Body support
Part-No.: 010.3658
Weight: appr. 0,73 kg

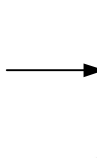

Compressed air hose
DN6/DN9 300mm long

