

# High Pressure Gun

## HP 1500S-V – E – 24V – Z

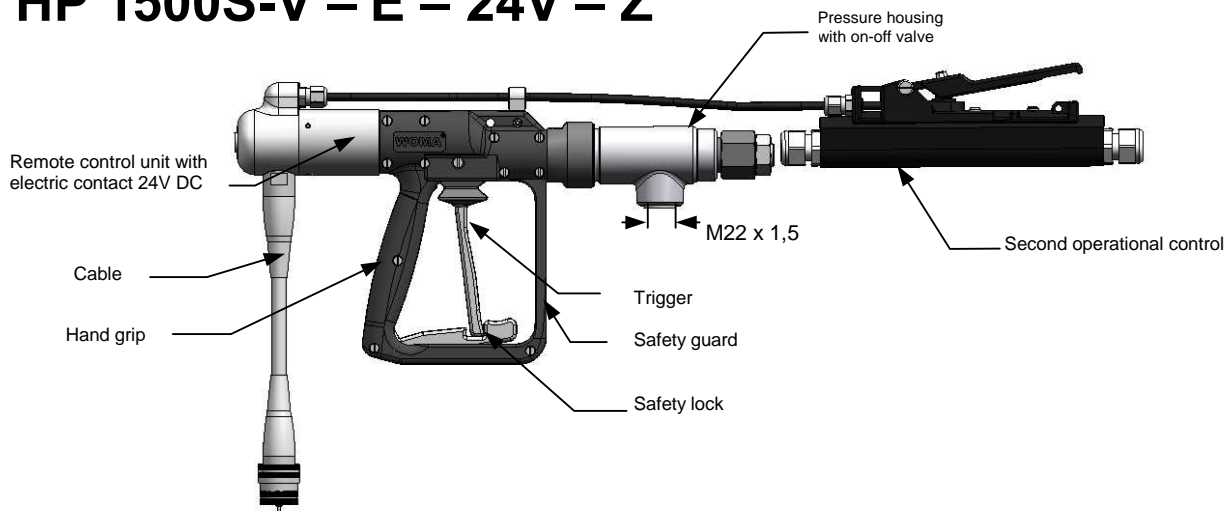

### Description:

The HP 1500S-V - E-24V-Z is a positive shutoff type high pressure jetting gun with two hand operation, which incorporates an internal on/off valve and low voltage micro switch into its design.

The second operational control increases safety standard.

Via the electric contacts, the high pressure operation of the unit can be switched on or off. This facilitates work and increases worker safety.

Standard equipment includes; a trigger safety guard and latching trigger lock to prevent unintentional use, forged steel pressure housing and light weight polymerized hand grip.

### Special Advantages:

- High safety standard.
- Two hand operation..
- Turnable hand grip for easy operation.
- Fully encapsulated polymerized hand grip offers high tensile strength and excellent resistant to most chemicals.
- All functional parts are protected from dirt and water invasion.

### Technical Data:

Part-No.:	001.1688
Operating pressure:	max. 1500 bar
Medium temperature:	max. 100 °C
Recoil force perm. without body support:	max. 150 N
Recoil force perm. with body support:	max. 250 N
Weight:	appr. 3 kg
Length ( second operational control incl.):	ü. a. 700 mm
Height:	ü. a. 200 mm
Width:	ü. a. 50 mm



Wasser als Werkzeug für eine saubere Umwelt

# HP 1500S-V – E – 24V – Z - Components

