

High Pressure Gun

HP 3000S-VDG

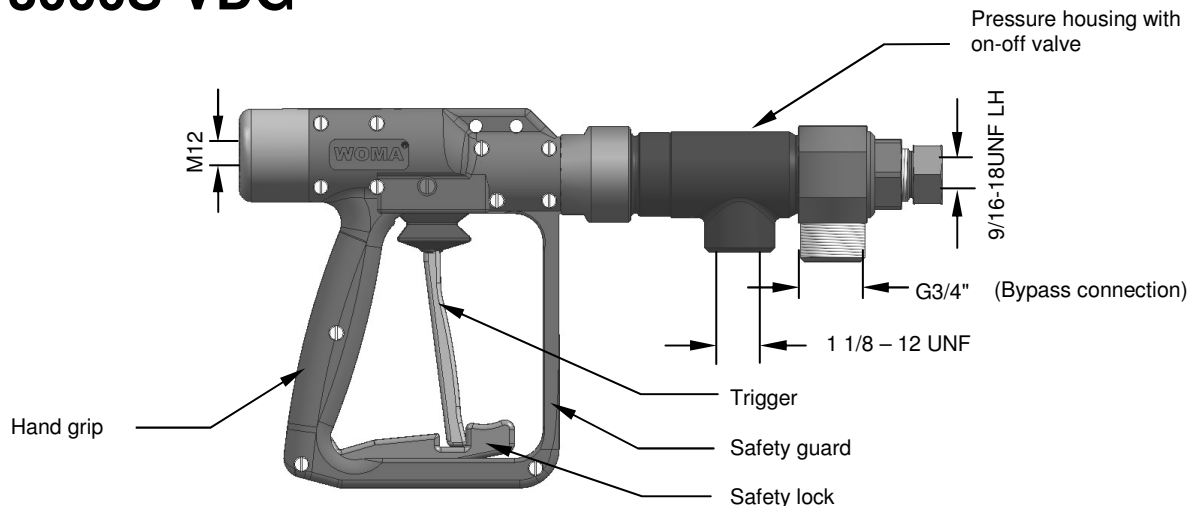

Description:

The HP 3000S-VDG is a positive shutoff type high pressure jetting gun which incorporates an internal on / off valve and a bypass for a max. operating pressure of 3000 bar.

In non actuating trigger position, the flow medium will be lead through the bypass line and the high pressure aggregate becomes pressureless.

Standard equipment includes; a trigger safety guard and latching trigger lock to prevent unintentional use, forged steel pressure housing and light weight polymerized hand grip.

Advantages:

- High safety standard
- Quick switching operation
- Turnable hand grip for easy operation
- Full encapsulated polymerized hand grip offers high tensile strength and excellent resistant to most chemicals.
- All functional parts are protected from dirt and water invasion.

Technical Data:

Part-No.:	001.1699
Operation pressure:	max. 3000 bar
Medium temperature:	max. 100 °C
Recoil force perm. without body support:	max. 150 N
Recoil force perm. with body support:	max. 250 N
Weight:	appr. 3 kg
Overall Length:	360 mm
Overall height:	200 mm
Overall width:	50 mm



Wasser als Werkzeug für eine saubere Umwelt

HP 3000S-VDG - Components

