

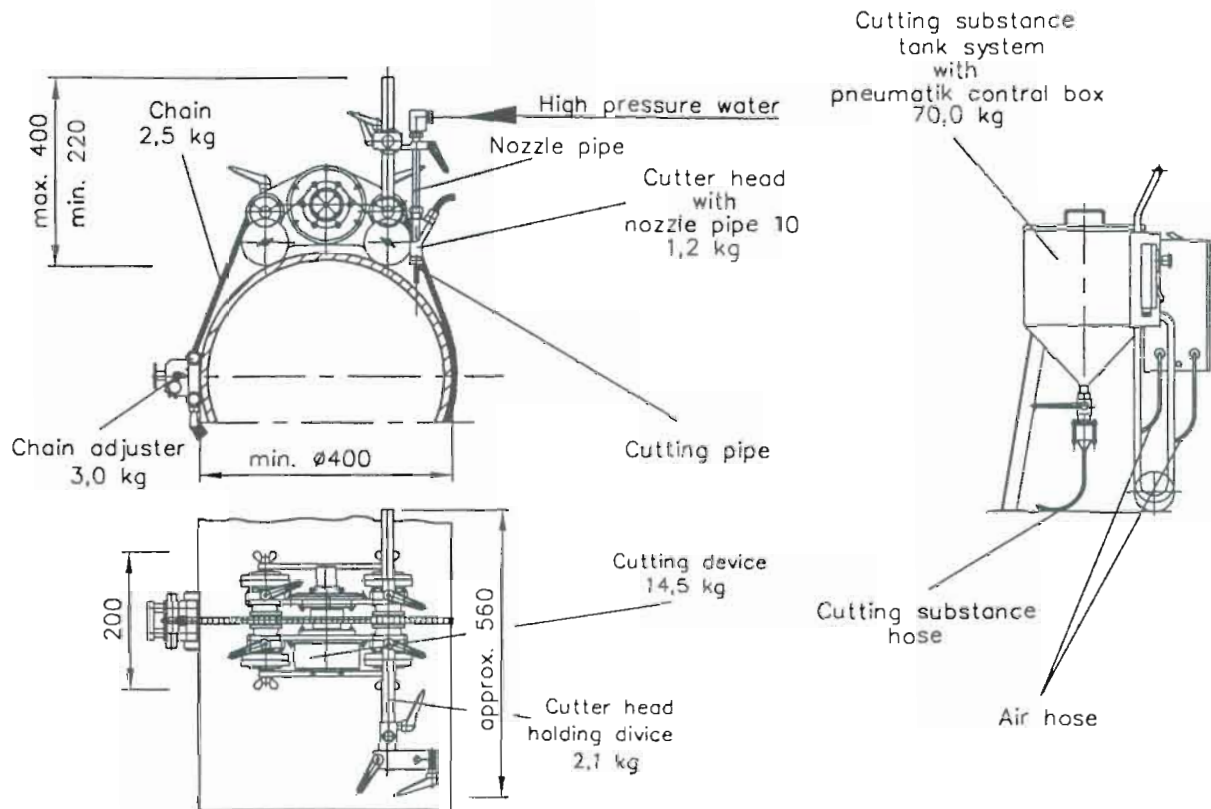

ECO Top Cutter ETC 3000-1-R-S



Description:

The ECO Top Cutter "ETC 3000-1-R-S" for cuts at round containers at high driving speed and small material thickness is used for cutting of metals, concrete and other materials. Via the nozzle pipe the high pressure water gets to the cutter head. In the swirl chamber of the cutter head there is built up a low pressure after the water jet has passed the nozzle form 10.

Consequently, the admixing of the cutting substance is made according to the injection principle, this means, it is suctioned in the cutter head. A dosed quantity of the cutting substance is taken from the cutting substance tank system.

The cutting device is driven by an air motor.

For linear cuts you need:

Exterior model f. cutting Part-No. 010.6169
and

Rail system complete Part-No. 010.6178

See product sheet Z-123-3000-1E+2E

Technical data:

Part-No.	:	001.1356
Operating pressure	:	max. 3000 bar
Max. air consumption	:	400l/min at 6 bar
Driving speed	:	min. 70 mm/min. max. 220 mm/min.
Material thickness	:	Steel up to 40mm Concrete up to 500mm
Recommended cutting substance	:	Garnet sand HS 5 0,5 mm - 1,0 mm
Total weight	:	approx. 103 kg
Nozzle form 10	:	1xØ1,0mm PN 340.1010 at 2000bar and 20l/min
Recommended nozzle diameter	:	1xØ0,9mm PN 340.1009 at 2500bar and 20l/min 1xØ0,8mm PN 340.1008 at 3000bar and 18l/min

Advantages:

- To cut off compound material resp. material combinations by one cut
- No thermal and mechanic stress at the cut edges resp. checked edges